



COMPANY PROFILE

ENGINEERING PRODUCTS
TRADING/MANUFACTURING COMPANY

SPECIALIZED IN FLUID HANDLING EQUIPMENTS/
TREATMENT SYSTEMS

FLUID SOLUTIONS WITH QUALITY



“ To facilitate end users with quality and cost effective fluid solutions”



“Our mission is to act as a bridge between end user and renowned partners to satisfy their needs through unique combination of skills and technology in a professional manner and strive to achieve excellence in every solution we provide without compromising on the quality”

CORPORATE INFORMATION

Company Name : M/s. Fluidtec Traders

Registered Address : 407, 4th Floor, AlQadir Heights, Lahore
Pakistan

Telephone # : +92 (300) 4016790

E-mail : fluidtetraders@gmail.com
: Imran@fluidtetraders.com

Website : www.fluidtetraders.com

NTN : 3465470-4

GST : 0300346547016

Key Personnel : Mr.Imran Shahid (Marketing)

INTRODUCTION

We would like to introduce ourselves as an engineering products manufacturing /trading company dealing in the field of fluid handling equipment.

Our goal is to provide best possible fluid solutions with quality and competitive price to our prestigious customers. We believe in customer's satisfaction by providing reliable solutions to meet their needs. We deal in following products:

- **Water Treatment System & Wastewater Treatment Systems**
- **Water Pumps (Self Priming, Submersible , Vertical, Horizontal, Inline, Booster and Firefighting Units)**
- **Chemical Transfer Pumps (Magnetic Drive Pumps ,Mechanical seal Pumps , Drum Empty Pumps)**
- **Metering and Double Diaphragm Pumps**
- **Mixers for small/ medium / large tanks (horizontal / vertical)**
- **Instrumentation, Valves**
- **Cartridges(Air, Liquid),Cartridge Housings, FRP Vessels,**
- **Water Treatment Chemicals**
- **Dosing Systems**
- **UV Systems**
- etc

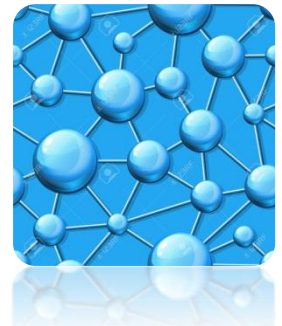

PH & ORP CHEMICAL CONTROLLER INSTALLATION DIAGRAM

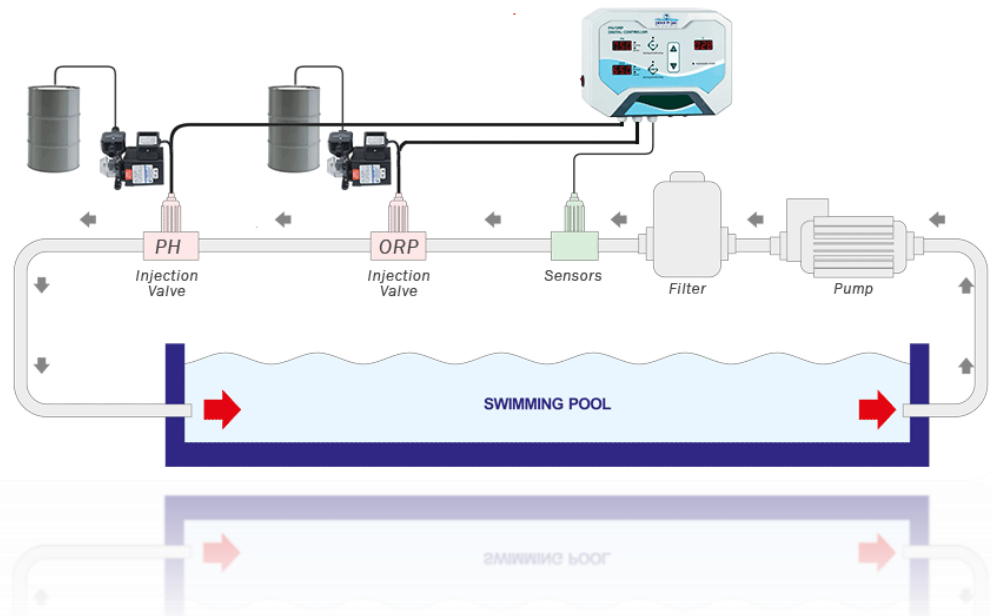

MARKET SECTORS

Our core business area in the following sectors:



Oil & Gas



Power



Textile



Water
& wastewater
treatment



Chemical



Pharmaceutical



Food & Beverages



PRODUCT GALLERY

WATER TREATMENT SYSTEM



AIR BUBBLE DIFFUSERS



DOSING SYSTEM

AIR OPERATED DOUBLE DIAPHRAGM



MIXERS



CHEMICAL TRANSFER PUMPS



WATER PUMPS/BOOSTER SYSTEMS



INSTRUMENTATION



WATER TREATMENT CHEMICALS



CLIENTS

